

ZAMA RB ROTARY CARBURETOR

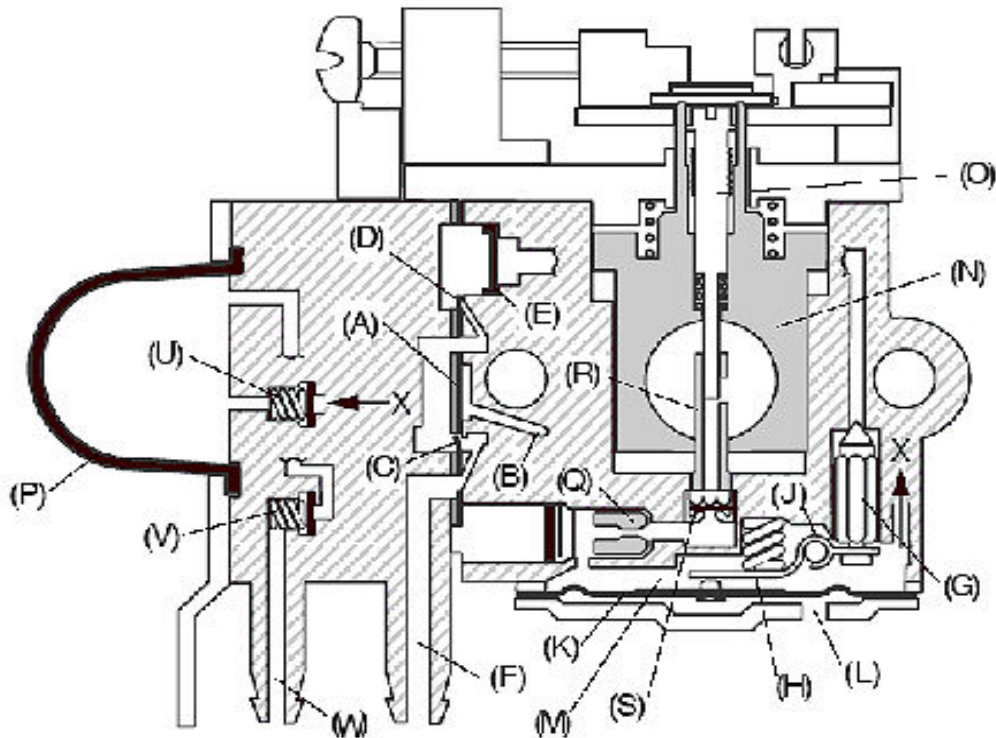

- (A) **Pump diaphragm** : Fluctuates in response to crankcase pulses. Transfers fuel from the tank to the inlet needle valve.
- (B) **Crankcase pulse** : Actuates fuel pump diaphragm with alternating positive and negative pressure pulses.
- (C) **Fuel pump inlet check valve** : Opens during negative pressure pulse. Closes during positive pressure pulses.
- (D) **Fuel pump outlet check valve** : Closes during negative pressure pulse. Opens during positive pressure pulse.
- (E) **Inlet screen** : Filters fuel in route to metering chamber.
- (F) **Fuel inlet** : Draws fuel from tank.
- (G) **Inlet needle valve** : Lifts off seat to allow fuel entering metering chamber.
- (H) **Metering lever spring** : Transmits force to metering lever. Closes inlet needle valve as metering chamber is filled.
- (J) **Metering lever** : Lifts inlet needle valve out of seat.
- (K) **Metering diaphragm** : Depressed by atmospheric pressure to activate metering lever.
- (L) **Atmospheric vent** : Allows atmospheric pressure onto dry side of metering diaphragm.
- (M) **Metering chamber** : Fuel reservoir, feeds fuel to main nozzle.
- (N) **Throttle valve** : Regulates engine speed, as controlling the air volume mixed with discharged fuel from main nozzle.
- (O) **Throttle valve needle** : Controls fuel at main nozzle.
- (P) **Purge bulb** : Pumps fuel from the fuel tank through the carburetor fuel pumps and metering chamber back to the fuel tank, purging air from the carburetor.
- (Q) **Main jet** : Meters correct amount of fuel to be delivered to main nozzle.
- (R) **Main nozzle** : Discharges fuel metered by main nozzle to mix with air at throttle valve.
- (S) **Main jet check valve** : Closes to prevent air from entering metering chamber when purge pump is operating.
- (U) **Inlet check valve** : Allows fuel to be sucked up to purge bulb.
- (V) **Outlet check valve** : Allows fuel to be forced to fuel return fitting.
- (W) **Fuel return fitting** : Return fuel to tank through return pipe.

PRINCIPLES OF OPERATION

PRIMER PURGE PUMP

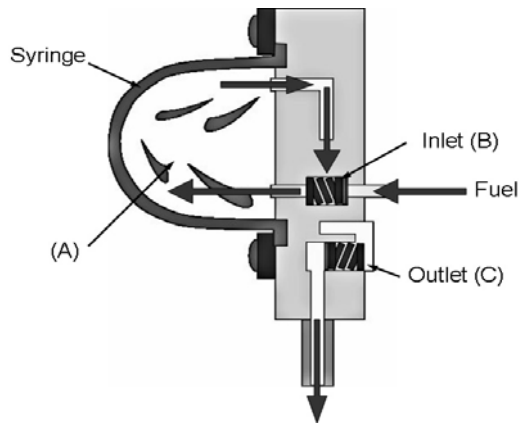

- The purge pump is comprised of purge bulb (A), inlet check valve (B) and outlet check valve (C).
- When the purge bulb (A) is depressed, the outlet check valve (C) opens and air or fuel is forced through the outlet check valve (C) to the fuel return hose fitting.
- When the purge bulb (A) is released, the outlet check valve (C) closes and the inlet check valve (B) opens to draw fuel from the metering chamber.
- Vacuum created by the expanding bulb draws fuel from the fuel tank through the fuel passages of the carburetor into the purge bulb (A).

THROTTLE BODY

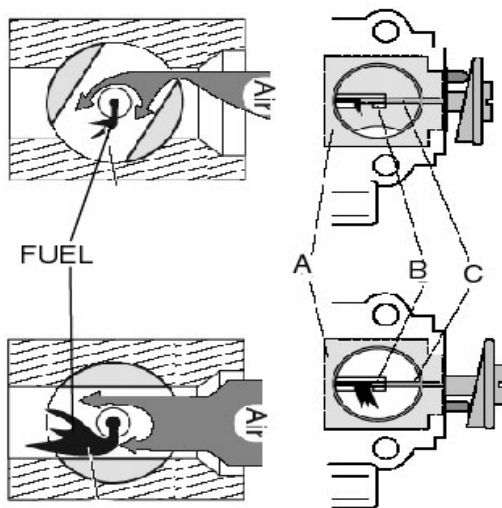

- The throttle valve (A) is a hollow barrel. Rotation of the throttle valve controls the opening of the throttle and also controls the air volume.
- The main nozzle (B) has a slot port to discharge and is located in the center of the throttle valve for maximum air velocity. The throttle valve needle (C) is installed into the main nozzle to control fuel volume. The throttle valve needle moves upward by cam action of the throttle valve, proportionate to the opening the throttle valve.
- At idle the throttle valve is slightly open. The valve needle is at its lowest position, the main nozzle only slightly open.
- As the throttle is opened, the opening of the valve enlarges to allow more airflow into the valve and simultaneously raises the throttle valve to increase fuel flow from the main nozzle.

FUEL PUMP

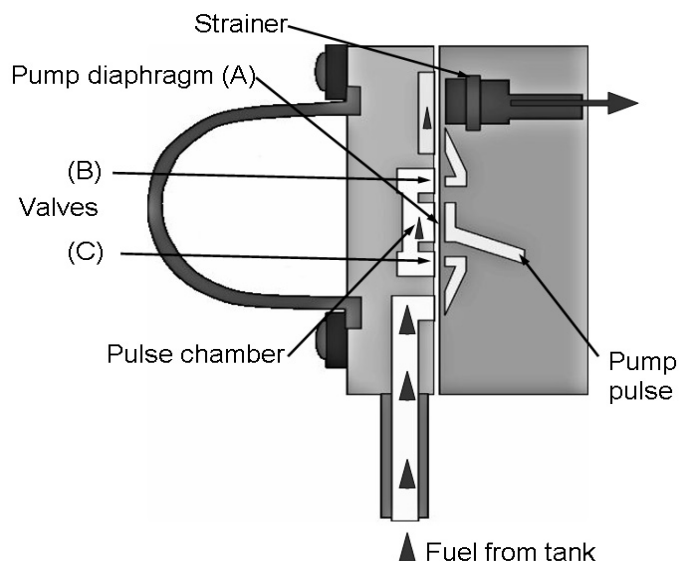

- The diaphragm (A) is operated by alternating positive pressure and negative pressure pulses generated in the crankcase.
- The valve (B) and (C) open and close alternately to direct the fuel flow from the fuel tank to the inlet needle valve. Fuel is filtered by the strainer prior to entering the metering chamber.

METERING CHAMBER AND INLET NEEDLE

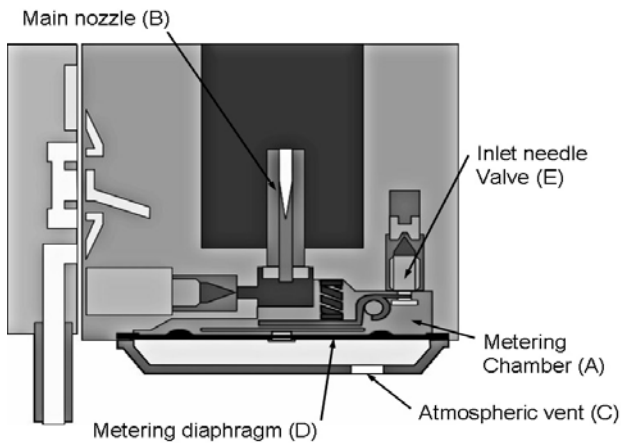

- The metering chamber (A) functions as a reservoir for fuel.
- As the engine rotates, air is drawn into the throttle valve by crankcase vacuum. This creates depression in the area of the main nozzle (B).
- Atmospheric pressure acting through the atmospheric vent (C) depresses the metering diaphragm (D) forcing fuel from the main nozzle (B) and simultaneously opening the inlet needle valve (E) to allow fuel into the metering chamber (A).
- The metering diaphragm controls the amount of fuel in the metering chamber.

RB ROTARY DISASSEMBLY AND SERVICE

FUEL PUMP

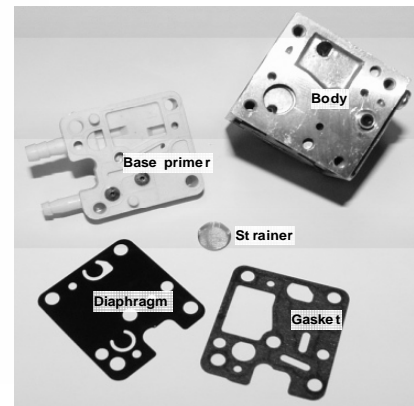
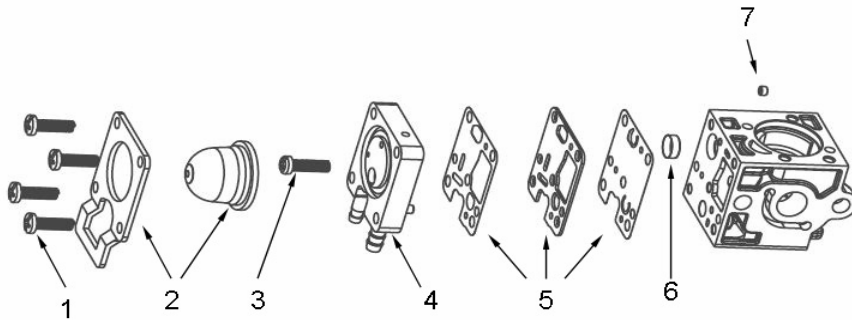

1. Remove four syringe retainer screws.
2. Remove syringe retainer and syringe.
3. Remove base primer screw. Remove base primer. Replace if primer does not function.
4. Remove surge diaphragm, pump gasket, and pump diaphragm.
5. Inspect pump diaphragms and gasket, replace if they show any signs of wear, wrinkles, curling or tears.
6. Remove fuel strainer installed in the carburetor body. Inspect for dirt and foreign matter. Replace if necessary.
7. Inspect and clean roller. Pay attention when disassembling carb to remove the roller and set aside so that it is not misplaced when cleaning the body.

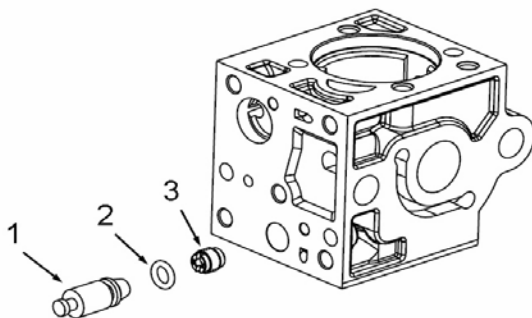

1. Remove plastic nozzle plug.
2. Inspect nozzle plug and o-ring. Replace if they show any signs of wear.
3. Remove jet. Inspect for damage. Do not run drill or wire through jet for cleaning.

METERING DIAPHRAGM AND INLET NEEDLE VALVE

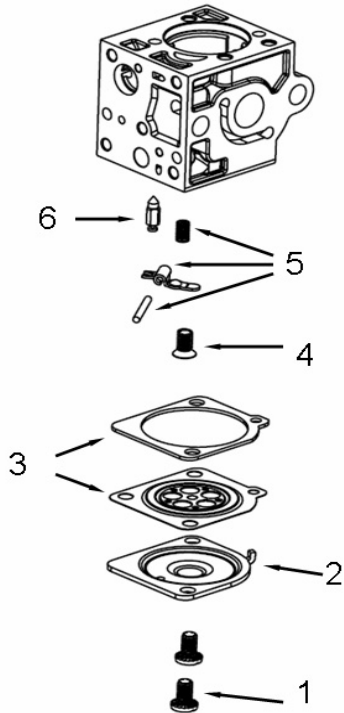

1. Remove two metering cover screws.
2. Remove metering chamber cover.
3. Remove metering diaphragm assembly and metering cover gasket. Inspect metering diaphragm for dirt and foreign matter, replace if they show any signs of wear, wrinkles, curling or tears.
4. Remove metering lever screw.
5. Remove the metering lever, pin and spring. Inspect the metering lever; it should not be worn where it contacts the inlet needle valve or pin. Replace if necessary.
6. Remove and inspect the inlet needle valve. The tip should not be deformed where it contacts the seat. A ring on the needle tip is normal. When you run your thumbnail across the surface of the tip you should not feel groove. Replace it if necessary.

Adjustment of metering lever for RB models

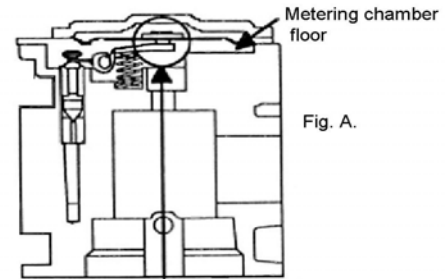

Free end of metering lever is about flush with the gasket flange of the carburetor body.

NOZZLE

- Nozzle Assembly cannot be removed.
- Clean with aerosol cleaner and compressed air.

ROTOR

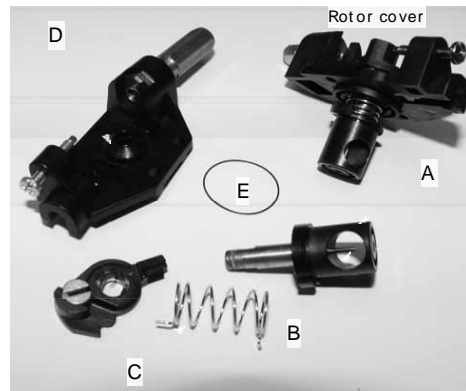
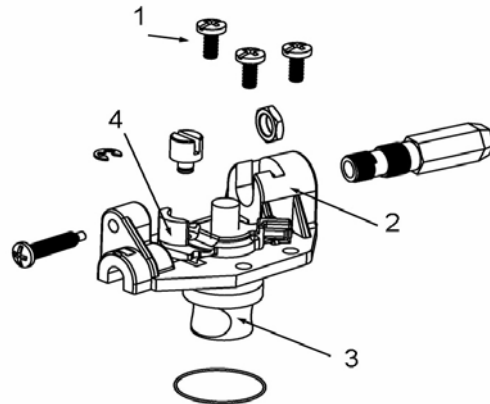

1. Remove two rotor cover screws.
2. Remove rotor cover carefully.
3. Inspect rotor for damage. Rotor assembly should not be broken or worn. Areas to look for wear are A) rotor B) jet needle C) return spring D) boot E) O-ring.
4. Remove Rotor guide carefully. The plastic guide must be smooth and free from cracks or chipped edges.

CARBURETOR BODY

- Clean the carburetor body. Channels can be cleaned with aerosol cleaner and or compressed air. Do not use wires or drills to clean the orifices. Inspect the operation of the throttle valve and lever.